

THERMA V™ R410A SPLIT HYDRO BOX

PRODUCT SPECIFICATION

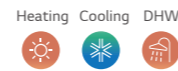

Indoor Unit

HN1616M NK5
HN1636M NK5

Outdoor Unit

HU121MA U33
HU141MA U33
HU161MA U33
HU123MA U33
HU143MA U33
HU163MA U33

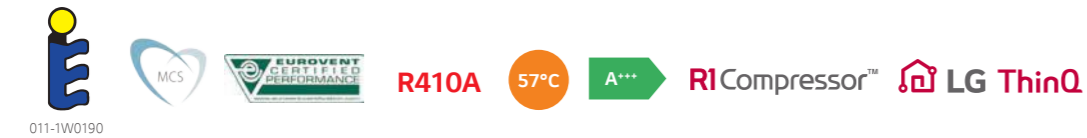

Features

- Refrigerant pipes connects IDU & ODU
- SCOP up to 4.65 (Average climate / Low temp. application): A+++
SCOP up to 3.37 (Average climate / Mid temp. application): A++
- COP up to 4.55 (Outdoor air 7°C / Leaving water 35°C)
- 100% heating capacity at -7 °C OAT (@ LWT 35°C)
- Wide operation range (ambient: -25 ~ 35°C / water side: 15 ~ 65°C)
- Built-in water flow & pressure sensors to monitor real-time water circuit
- R1 compressor
- Gold Fin heat exchanger
- LG ThinQ
- KEYMARK / MCS / EUROVENT certification

* EHPA label under development

Model Line-up

Category	Unit	Model Name		
		Capacity (kW)		
		12.0	14.0	16.0
1 Phase Model 220 - 240V, 1Ø, 50Hz	Outdoor Unit	HU121MA U33	HU141MA U33	HU161MA U33
	Indoor Unit	HN1616M NK5		
3 Phase Model 380 - 415V, 3Ø, 50Hz	Outdoor Unit	HU123MA U33	HU143MA U33	HU163MA U33
	Indoor Unit	HN1636M NK5		

Seasonal Energy

Description			Outdoor Unit				
			HU121MA U33 (1Ø)	HU141MA U33 (1Ø)	HU161MA U33 (1Ø)		
			HU123MA U33 (3Ø)	HU143MA U33 (3Ø)	HU163MA U33 (3Ø)		
Space Heating (according to EN14825)	Average Climate Water Outlet 35°C	SCOP	-	4.65	4.61	4.56	
		Seasonal Space Heating Efficiency (η _s)	%	183	182	179	
	Average Climate Water Outlet 55°C	SCOP	-	3.36	3.37	3.32	
		Seasonal Space Heating Efficiency (η _s)	%	131	132	130	
			Seasonal Space Heating Eff. Class (A+++ to D scale)	-	A+++	A+++	A+++
					HN1616M NK5 (1Ø)		
				HN1636M NK5 (3Ø)			

Nominal Capacity and Nominal Power Input

Description		OAT (DB)	LWT (DB)	Outdoor Unit			
				HU121MA U33 (1Ø)	HU141MA U33 (1Ø)	HU161MA U33 (1Ø)	
				HU123MA U33 (3Ø)	HU143MA U33 (3Ø)	HU163MA U33 (3Ø)	
Nominal Capacity	Heating	7°C	35°C	kW	HN1616M NK5 (1Ø)		
		7°C	55°C		HN1636M NK5 (3Ø)		
		2°C	35°C		12.00	14.00	16.00
	Cooling	35°C	18°C		11.00	12.00	13.80
		35°C	7°C		10.40	12.00	13.00
		7°C	35°C		7.94	8.50	8.92
Nominal Power Input	Heating	7°C	35°C	kW	2.64	3.17	3.76
		7°C	55°C		4.31	4.51	4.71
		2°C	35°C		3.04	3.32	3.83
	Cooling	35°C	18°C		2.60	3.08	3.60
		35°C	7°C		2.66	3.02	2.53
		7°C	35°C		4.55	4.41	4.26
COP	Heating	7°C	35°C	W/W	2.55	2.55	2.55
		7°C	55°C		3.62	3.61	3.60
		2°C	35°C		4.00	3.90	3.61
EER	Cooling	35°C	18°C	W/W	2.98	2.81	3.53
		35°C	7°C				

PRODUCT SPECIFICATION

R410A Split Hydro Box

Product Specification (Outdoor Unit)

Technical Specification			Unit	HU121MA U33	HU141MA U33	HU161MA U33	HU123MA U33	HU143MA U33	HU163MA U33
Operation Range (outdoor temp.)	Heating	Min. - Max.	°C DB	-25 ~ 35					
	Cooling								
Compressor	Quantity			1					
	Type			Hermetic Sealed Scroll					
Refrigerant	Type			R410A					
	GWP (global warming potential)			2,088					
	Precharged Amount			2,500					
	t-CO ₂ eq			5,219					
Piping Connections	Outside Diameter	Gas	mm (inch)	Φ 15.88 (5/8)					
		Liquid	mm (inch)	Φ 9.52 (3/8)					
	Length	Standard	m	7.5					
		Max.	m	50					
	Level Difference	Max.	m	30					
	Chargeless-Pipe Length		m	7.5					
Additional Charging Volume		g/m	40						
Rated Water Flow Rate (at LWT 35°C)			LPM	34.5	40.3	46.0	34.5	40.3	46.0
Sound Power Level	Heating	Rated	dB(A)	63	64	65	63	64	65
	Cooling								
Sound Pressure Level (at 1m)	Heating	Rated	dB(A)	55	56	57	55	56	57
	Cooling								
Dimensions	Unit	W x H x D	mm	950 x 1,380 x 330					
Weight	Unit		kg	84.8			85.4		
Exterior	Color / RAL Code			Warm Gray / RAL 7044					
Power Supply	Voltage, Phase, Frequency		V, Ø, Hz	220-240, 1, 50			380-415, 3, 50		
	Rated Running Current	Heating	A	11.5	13.8	16.3	6.6	8.0	9.4
		Cooling	A	11.3	13.4	15.7	6.5	7.7	9.0
Recommended Circuit Breaker		A	40			20			
Wiring Connections	Power Supply Cable (included earth, H07RN-F)		mm ² x cores	6.0 x 3C			2.5 x 5C		

Note

- Due to our policy of innovation some specifications may be changed without notification.
- Wiring cable size must comply with the applicable local and national codes. Especially the power cable and circuit breaker should be selected in accordance with that.
- Sound power level is measured on the rated condition in accordance with ISO 9614 standard. Sound pressure level is converted from sound power level based on tonality penalty of 0dB and installation in free-field. Therefore, these values can be increased owing to ambient conditions during operation. Rated sound power level is according to the EN12102-1 under conditions of the EN14825.
- Performances are based on the following conditions (It is according to EN14511):
 - Interconnected Pipe Length is standard length and difference of Elevation (Outdoor - Indoor Unit) is 0m.
- This product contains Fluorinated greenhouse gases. (Outdoor - Indoor Unit)

Product Specification (Indoor Unit)

Technical Specification			Unit	HN1616M NK5	HN1636M NK5
Operation Range (leaving water)	Heating	Min. - Max.	°C DB	15 ~ 57	
	Cooling			5 ~ 27 (16 ~ 27) ¹⁾	
	DHW			15 ~ 80 ²⁾	
Flow Sensor	Measuring Range	Min. - Max.	LPM	5 ~ 80	
Water Pressure Sensor	Measuring Range	Min. - Max.	bar(G)	0 ~ 20	
Expansion Vessel	Volume		ℓ	8	
Safety Valve	Pressure Limit	Upper Limit	bar	3	
	Type			Sheath	Sheath
Backup Heater	Number of Heating Coil		EA	2	3
	Capacity Combination		kW	3.0 + 3.0	2.0 + 2.0 + 2.0
	Heating Steps		Step	2	2
	Power Supply		V, Ø, Hz	220-240, 1, 50	380-415, 3, 50
	Rated Running Current		A	25.0	8.7
	Power Supply Cable (included earth, H07RN-F)		mm ² x cores	4.0 x 3C	2.5 x 4C
Piping Connections	Water Circuit	Inlet	Inch	Male PT 1" according to ISO 7-1 (tapered pipe threads)	
		Outlet	Inch	Male PT 1" according to ISO 7-1 (tapered pipe threads)	
	Refrigerant Circuit	Gas (outside diameter)	mm (Inch)	Ø 15.88 (5/8)	
		Liquid (outside diameter)	mm (Inch)	Ø 9.52 (3/8)	
Wiring Connections	Power and Communication Cable (included earth, H07RN-F)		mm ² x cores	0.75 x 4C	
Sound Power Level	Heating	Rated	dB(A)	44	
Dimensions	Unit	W x H x D	mm	490 x 850 x 315	
Weight	Unit		kg	40.0	41.0
Exterior	Color / RAL Code			Noble White / RAL 9016	

1) When fan coil unit not used.

2) DHW 58-80°C Operating is available only when the booster heater is operating.

Note

- Due to our policy of innovation some specifications may be changed without notification. Especially the power cable and circuit breaker should be selected in accordance with that.
- Wiring cable size must comply with the applicable local and national codes. Especially the power cable and circuit breaker should be selected in accordance with that.
- Sound power level is measured on the rated condition in accordance with ISO 9614 standard. Sound pressure level is converted from sound power level based on tonality penalty of 0dB and installation in free-field. Therefore, these values can be increased owing to ambient conditions during operation. Rated sound power level is according to the EN12102-1 under conditions of the EN14825.
- This product contains Fluorinated greenhouse gases.

PRODUCT SPECIFICATION

Performance Table for Heating Operation

Maximum Heating Capacity (Including Defrost Effect)

HU121MA U33 + HN1616M NK5 / HU123MA U33 + HN1636M NK5

Outdoor Temperature	LWT 30 °C	LWT 35 °C	LWT 40 °C	LWT 45 °C	LWT 50 °C	LWT 55 °C
	TC	TC	TC	TC	TC	TC
-20°C DB	11.25	10.95	10.22	9.85	-	-
-15°C DB	12.00	11.32	10.90	10.32	-	-
-7°C DB	12.00	11.66	11.45	11.16	11.13	-
-4°C DB	12.00	12.00	12.00	12.00	12.00	11.24
-2°C DB	12.00	12.00	12.00	12.00	12.00	11.98
2°C DB	12.00	12.00	12.00	12.00	12.00	12.00
7°C DB	12.00	12.00	12.00	12.00	12.00	12.00
10°C DB	12.00	12.00	12.00	12.00	12.00	12.00
15°C DB	12.00	12.00	12.00	12.00	12.00	12.00
18°C DB	12.00	12.00	12.00	12.00	12.00	12.00
20°C DB	12.00	12.00	12.00	12.00	12.00	12.00
35°C DB	12.00	12.00	12.00	12.00	12.00	12.00

HU141MA U33 + HN1616M NK5 / HU143MA U33 + HN1636M NK5

Outdoor Temperature	LWT 30 °C	LWT 35 °C	LWT 40 °C	LWT 45 °C	LWT 50 °C	LWT 55 °C
	TC	TC	TC	TC	TC	TC
-20°C DB	11.25	11.17	10.79	10.32	-	-
-15°C DB	12.11	11.98	11.54	10.90	-	-
-7°C DB	13.06	12.99	12.77	12.27	12.42	-
-4°C DB	14.00	14.00	14.00	13.64	13.09	11.67
-2°C DB	14.00	14.00	14.00	14.00	14.00	12.67
2°C DB	14.00	14.00	14.00	14.00	14.00	13.98
7°C DB	14.00	14.00	14.00	14.00	14.00	14.00
10°C DB	14.00	14.00	14.00	14.00	14.00	14.00
15°C DB	14.00	14.00	14.00	14.00	14.00	14.00
18°C DB	14.00	14.00	14.00	14.00	14.00	14.00
20°C DB	14.00	14.00	14.00	14.00	14.00	14.00
35°C DB	14.00	14.00	14.00	14.00	14.00	14.00

HU161MA U33 + HN1616M NK5 / HU163MA U33 + HN1636M NK5

Outdoor Temperature	LWT 30 °C	LWT 35 °C	LWT 40 °C	LWT 45 °C	LWT 50 °C	LWT 55 °C
	TC	TC	TC	TC	TC	TC
-20°C DB	12.27	12.01	11.48	10.86	-	-
-15°C DB	13.11	12.90	12.62	12.30	-	-
-7°C DB	13.73	13.70	13.46	13.16	12.42	-
-4°C DB	14.36	14.50	14.30	14.01	13.40	12.50
-2°C DB	15.20	14.80	14.50	14.25	14.00	13.50
2°C DB	16.00	16.00	16.00	16.00	16.00	14.51
7°C DB	16.00	16.00	16.00	16.00	16.00	16.00
10°C DB	16.00	16.00	16.00	16.00	16.00	16.00
15°C DB	16.00	16.00	16.00	16.00	16.00	16.00
18°C DB	16.00	16.00	16.00	16.00	16.00	16.00
20°C DB	16.00	16.00	16.00	16.00	16.00	16.00
35°C DB	16.00	16.00	16.00	16.00	16.00	16.00

Note
 1. DB : Dry Bulb Temperature (°C), LWT : Leaving Water Temperature (°C), LPM : Liters Per Minute (l/min), TC : Total Capacity (kW)
 2. Direct interpolation is permissible. Do not extrapolate.
 3. Measuring procedure follows EN-14511.
 • Rated values are based on standard conditions and it can be found on specifications.
 • Above table values may not be matched according to installation condition. Except for rated value, the performance is not guaranteed.
 • In accordance with the test standard (or nations), the rating will vary slightly.
 4. The shaded areas are not guaranteed continuous operation.

Performance Table for Cooling Operation

Maximum Cooling Capacity

HU121MA U33 + HN1616M NK5 / HU123MA U33 + HN1636M NK5

Outdoor Temperature	LWT 7°C	LWT 10°C	LWT 13°C	LWT 15°C	LWT 18°C	LWT 20°C	LWT 22°C
	TC	TC	TC	TC	TC	TC	TC
20°C DB	7.60	8.55	9.51	10.33	11.19	11.98	-
30°C DB	8.62	9.05	9.78	10.67	10.90	11.37	-
35°C DB	7.94	8.66	9.33	10.10	10.40	10.75	11.16
40°C DB	7.56	8.02	8.81	9.36	9.54	9.89	10.28
45°C DB	6.38	7.08	7.79	8.44	9.14	9.44	9.78

HU141MA U33 + HN1616M NK5 / HU143MA U33 + HN1636M NK5

Outdoor Temperature	LWT 7°C	LWT 10°C	LWT 13°C	LWT 15°C	LWT 18°C	LWT 20°C	LWT 22°C
	TC	TC	TC	TC	TC	TC	TC
20°C DB	8.13	9.87	10.97	11.92	12.91	13.82	-
30°C DB	9.24	10.44	11.29	12.31	12.58	13.12	-
35°C DB	8.50	9.99	10.76	11.65	12.00	12.40	12.88
40°C DB	8.10	9.25	10.17	10.80	11.01	11.42	11.86
45°C DB	7.17	8.17	8.99	9.73	10.55	10.89	11.23

HU161MA U33 + HN1616M NK5 / HU163MA U33 + HN1636M NK5

Outdoor Temperature	LWT 7°C	LWT 10°C	LWT 13°C	LWT 15°C	LWT 18°C	LWT 20°C	LWT 22°C
	TC	TC	TC	TC	TC	TC	TC
20°C DB	8.54	10.69	11.89	12.91	13.98	14.97	-
30°C DB	9.70	11.31	12.22	13.34	13.63	14.21	-
35°C DB	8.92	10.82	11.66	12.63	13.00	13.43	13.96
40°C DB	8.51	10.03	11.02	11.70	11.93	12.37	12.85
45°C DB	7.52	8.85	9.73	10.55	11.42	11.80	12.16

Note
 1. DB : Dry Bulb Temperature (°C), LWT : Leaving Water Temperature (°C), LPM : Liters Per Minute (l/min), TC : Total Capacity (kW)
 2. Direct interpolation is permissible. Do not extrapolate.
 3. Measuring procedure follows EN-14511.
 • Rated values are based on standard conditions and it can be found on specifications.
 • Above table values may not be matched according to installation condition. Except for rated value, the performance is not guaranteed.
 • In accordance with the test standard (or nations), the rating will vary slightly.
 4. The shaded areas are not guaranteed continuous operation.

THERMA V™ R410A SPLIT HYDRO BOX

PRODUCT SPECIFICATION

Drawings

Category	Unit	Model Name		
		Capacity (kW)		
		12.0	14.0	16.0
1 Phase Model 220 - 240V, 1Ø, 50Hz	Outdoor Unit	HU121MA U33	HU141MA U33	HU161MA U33
	Indoor Unit		HN1616M NK5	
3 Phase Model 380 - 415V, 3Ø, 50Hz	Outdoor Unit	HU123MA U33	HU143MA U33	HU163MA U33
	Indoor Unit		HN1636M NK5	

HU121MA U33 / HU141MA U33 / HU161MA U33 /
HU123MA U33 / HU143MA U33 / HU163MA U33

[Unit : mm]

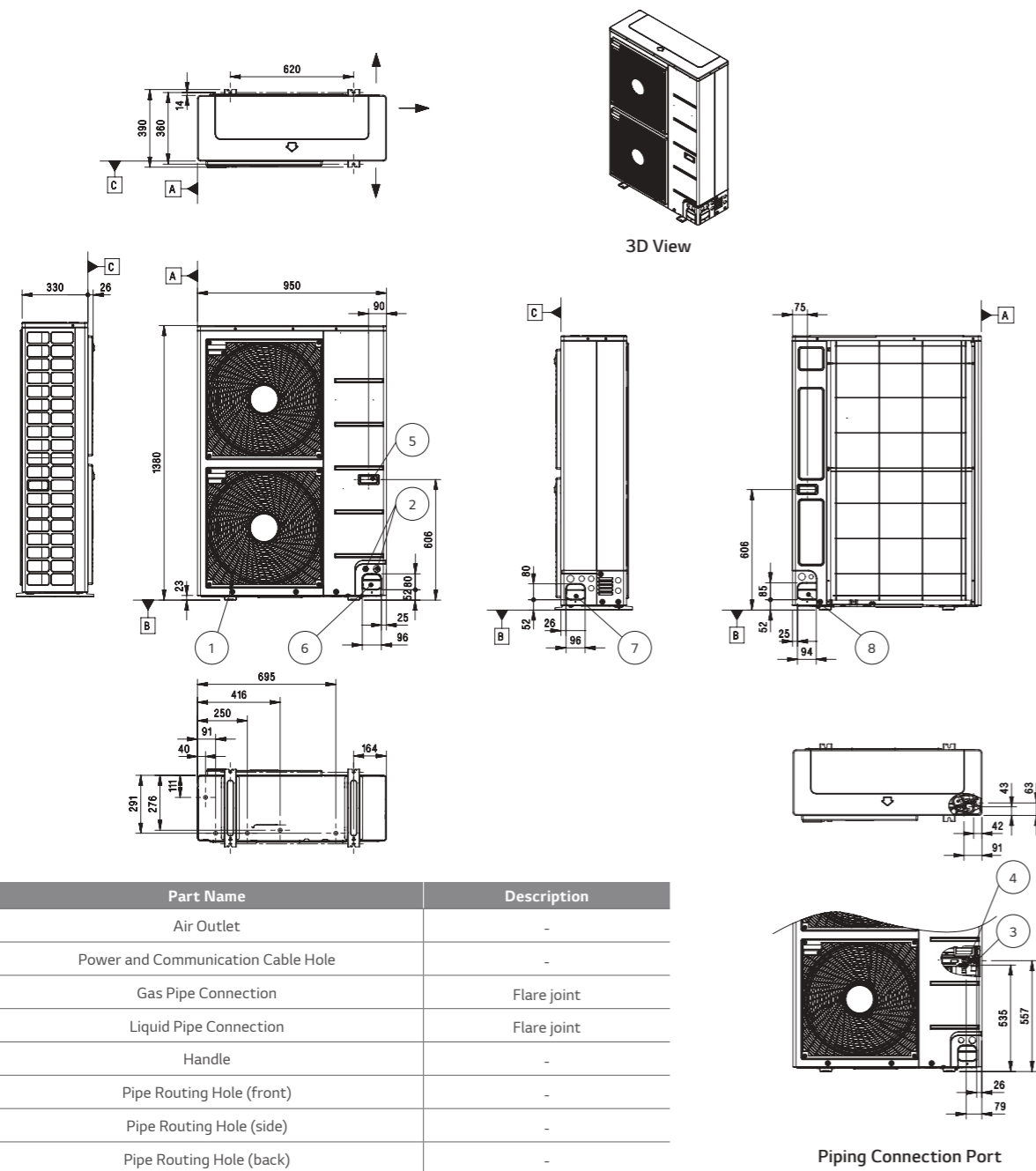

HN1616M NK5 / HN1636M NK5

[Unit : mm]

External

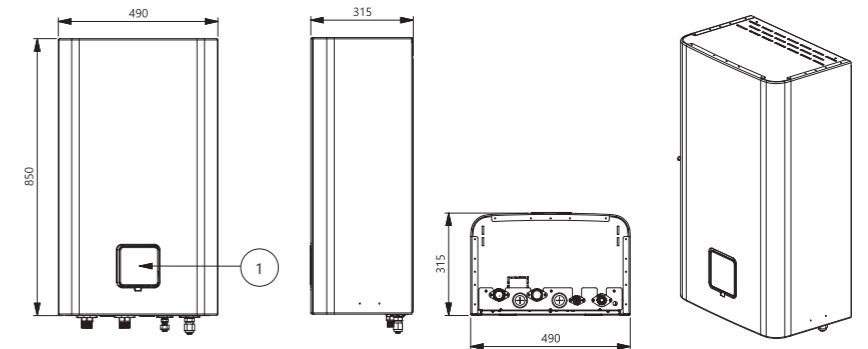

No.	Part Name	Description
1	Control Panel	Built-in remote controller

Internal

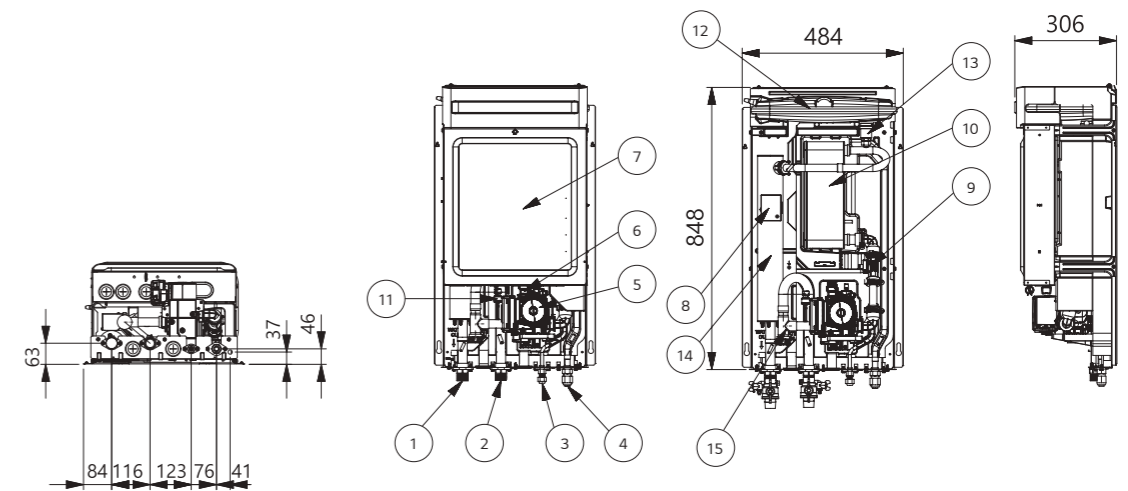

No.	Part Name	Description
1	Leaving Water Pipe	Male PT 1" according to ISO 7-1 (tapered pipe threads)
2	Entering Water pipe	Male PT 1" according to ISO 7-1 (tapered pipe threads)
3	Refrigerant Pipe (Liquid)	Ø9.52 (mm)
4	Refrigerant Pipe (Gas)	Ø15.88 (mm)
5	Water Pump	GROUNDFOSS UPML 20-105 CHBL
6	Safety Valve	Open at water pressure 3bar
7	Control Box	PCB and terminal blocks
8	Thermal Switch	Cut-off power input to electric heater at 90°C
9	Flow Sensor	SIKA VVX20 5-80LPM
10	Plate Heat Exchanger	Heat exchange between refrigerant and water
11	Pressure Sensor	SENSATA 2HMP3-04W, 0-2MPa
12	Expansion Tank	Absorbing volume change of heated water
13	Air Vent	Air purging when charging water
14	Backup Heater	6 kW
15	Strainer	Filtering and stacking particles inside circulating water